



Edwin I. Hatch Nuclear Plant Media Guide





Table of Contents

A guide for journalists	2
Southern Nuclear introduction	3
Safety and emergency planning	4
Managing a nuclear plant emergency	5
Emergency response facilities	6
Emergency classifications.....	7
Emergency notification systems.....	8
Public protective actions	9
Media contacts	10
Contacts for federal, state and local agencies	11
Plant Hatch facts and statistics	12
Our fuel	14
How Plant Hatch works	15
Storage of used fuel	16
Radiation.....	17
Who was Edwin I. Hatch?.....	18



A guide for journalists

Southern Nuclear developed this media guide to help journalists that cover Plant Hatch learn more about how we operate the plant to generate nuclear power, and the important role of the media in keeping the community informed.

We strive to give honest, straightforward answers to questions from the media about our plants and are available 24 hours a day via our media line.

Georgia Power Media Line: 800-282-1696

Southern Nuclear Media Line: 205-992-5395

We hope this information will help you cover stories about Plant Hatch. You are an important source of information to our customers and neighbors living near the plant. In the unlikely event of an emergency, your role in informing the public with timely, accurate information would be vital.

Please take time to read this media guide and call us with any questions you have. Contact the Hatch Energy Education Center at 1-800-722-7774.



Southern Nuclear introduction

Southern Nuclear, headquartered in Birmingham, Ala., operates Southern Company's six nuclear units at three locations: the Edwin I. Hatch Nuclear Plant near Baxley, Ga.; the Alvin W. Vogtle Electric Generating Plant near Waynesboro, Ga.; and the Joseph M. Farley Nuclear Plant near Dothan, Ala.

Plant Hatch and Plant Vogtle were built by and are co-owned by Georgia Power Company, Oglethorpe Power Corporation, Municipal Electric Authority of Georgia and Dalton Utilities. Together, these two nuclear plants generate approximately 25 percent of the electricity used in Georgia.

Southern Nuclear, Alabama Power and Georgia Power are wholly owned subsidiaries of Atlanta-based Southern Company (NYSE: SO). Southern Company is a leading energy company serving 9 million customers through our subsidiaries. We provide clean, safe, reliable and affordable energy through electric companies in three states, natural gas distribution companies in four states, a competitive generation company serving wholesale customers across America, a leading distributed energy infrastructure company, a fiber optics network and telecommunications services.

Southern Company brands are known for excellent customer service, high reliability and affordable prices below the national average. For more than a century, we have been building the future of energy and developing the full portfolio of energy resources, including carbon-free nuclear, advanced carbon capture technologies, natural gas, renewables, energy efficiency and storage technology.



Safety and emergency planning

Safety is the top priority at Plant Hatch. We take very seriously our obligation to protect the health and safety of our employees, the public and the environment.

Multiple layers of protection

Plant Hatch is designed with redundant safety systems and multiple layers of protection – including structural strength, highly trained operators and proven emergency plans – to ensure safe operation.

Regulatory oversight

Full-time, on-site inspectors from the U.S. Nuclear Regulatory Commission (NRC) monitor the plant to ensure it is maintained and operated safely and in accordance with established nuclear operating procedures. The NRC holds nuclear plants to the highest security standards of any American industry.

Emergency preparedness

In the unlikely event of an emergency, Plant Hatch has comprehensive plans that define and assign responsibilities and outline an effective course of action for safeguarding personnel, property and the general public. These plans are updated regularly and maintained at all times. Drills and exercises are conducted frequently to test these plans and train plant personnel.



Managing a nuclear plant emergency

Southern Nuclear has the overall responsibility for the Plant Hatch Emergency Plan, which involves Southern Nuclear, Georgia Power and various state, county and federal agencies. The emergency plan specifies the procedures, personnel and equipment that would be used to classify an emergency, to define and assign responsibilities and to outline an effective course of action for safeguarding personnel, property and the general public.

Plant Hatch technical staff is always on duty and trained to recognize and address plant problems before they become emergencies. If an emergency should occur, plant personnel are prepared to serve as the initial on-site emergency response organization. Depending on emergency severity, the on-site personnel would be supplemented and supported by additional Southern Nuclear and Georgia Power personnel.

Emergency support is available from a variety of other off-site organizations including:

- The U.S. Nuclear Regulatory Commission
- Georgia Emergency Management and Homeland Security Agency
- Georgia Department of Natural Resources
- The U.S. Department of Energy
- Other electric utility companies
- The Institute of Nuclear Power Operations
- The Nuclear Energy Institute

Should an emergency occur, one of the first steps would be to notify our off-site partners and local county officials. Communication would be maintained with these agencies to keep them fully aware of the emergency status, including on-site and off-site radiological information.

At the same time, employees would immediately take steps to restore the plant to a safe condition, monitor and control radiation, and manage and coordinate all emergency activities.



Emergency response facilities

(Georgia Power Corporate Media Center
Plant Hatch Joint Information Center)

If an emergency occurred at Plant Hatch, a Corporate Media Center (CMC) would be established at Georgia Power's Corporate Headquarters at 241 Ralph McGill Boulevard in Atlanta, to serve as an information center until the Plant Hatch Joint Information Center (JIC) is activated.

Depending on the severity of an emergency, the JIC would be activated for use by the news media. The JIC is located at 111 Fowler Street, Vidalia, GA 30474.

Once the facility is activated, media calls should be directed to 800-282-1696. Spokespersons from Georgia Power, Southern Nuclear and our local, state and federal partners responding to the event will be at the JIC to discuss their activities.

Media personnel arriving at the JIC should use the front entrance. The degree of activity at these and other off-site emergency facilities would depend on the severity of the emergency.



Plant Hatch Joint Information Center



Emergency classifications

There are four classifications used to describe accident severity of nuclear power plant emergencies. From least to most severe, the emergency classifications are:

Notice of Unusual Event

The least serious of the four NRC classifications. It means there is a minor problem at the plant. Because of strict federal regulations, many situations occur that qualify as unusual events. Unusual events pose no danger to the public. You will not need to take any actions unless directed to by state and local officials.

Alert

An event has occurred that could reduce the plant's level of safety. There should be no danger to the public. County and state officials will be involved and prepared for any necessary response. You will not need to take any actions unless directed to by state and local officials.

Site Area Emergency

An event has occurred that could involve major problems with plant systems. Local radio and television stations in the area will provide information and instructions. If you're in an affected area, you will be notified by state and local officials about any actions you need to take.

General Emergency

The most serious of the four NRC classifications. Radioactive material could be released outside the plant site. State and local authorities will take action to protect the public. Sirens may be sounded and local radio and television stations will provide information and instructions. If you're in an affected area, you will be notified by state and local officials about any actions you need to take.



Emergency notification systems

A variety of emergency notification systems would alert residents near Plant Hatch should an emergency occur. State and county officials would be immediately notified, and those officials would determine what systems to use to notify residents.

Siren systems

Sirens have been installed within the 10-mile Emergency Planning Zone (EPZ) around Plant Hatch. These sirens alert residents to listen to a local radio or television station. The sirens have a sound different from emergency vehicles. They are tested frequently and may sound briefly while routine maintenance is being conducted.

CodeRED emergency notification system

The CodeRED emergency notification system may be utilized to contact residents by phone in the event of an emergency. For additional information about CodeRED, contact your local emergency management agency.

Transient notifications

State and local vehicles are available for drive-through notification, and boats would be used to alert fishermen, hunters and other transient populations in the area around the plant. Signs and printed information are in place for visitors to the Emergency Planning Zone that instruct them where to receive additional information.



Public protective actions

The decision to initiate protective actions for plant neighbors will be made by the Georgia Emergency Management Agency and/or local emergency management agencies. Residents in the vicinity of the plant would be informed of the emergency by designated alert stations in the Emergency Alert System. For questions about how to respond to an emergency, please contact the GEMA and/or local EMAs.

If protective measures are required, state and county authorities would advise the public what action, if any, to take for protection. The three actions health officials might recommend are called take shelter, go inside/stay inside and evacuate.

Take shelter means to protect oneself by going inside a building and keeping out as much outside air as possible. Taking shelter would generally be advised if there were small amounts of radiation in the air. The Emergency Alert System would be the major source of information and instruction to the public.

Go inside/stay inside means protecting yourself by going inside any type of building, home or business. This action will keep you safe if there is a security event occurring at the plant. Radiation levels above EPA limits are not detected under this emergency action.

Evacuation may be ordered by government authorities during an emergency at the plant if they decide that the protection provided by taking shelter is insufficient. Citizens would be told to move to pre-designated reception centers outside the emergency area. Evacuation plans are part of the overall Plant Hatch Emergency Plan. These plans have been thoroughly researched and include provisions for transporting, routing and housing the public; protecting property; and handling virtually every conceivable difficulty during an evacuation. Public officials have been specifically trained to carry out these plans.

In any emergency event at Plant Hatch that requires protective actions to be issued, the utility and state and county officials would work closely with the media to ensure reporters have accurate information to disseminate to the general public.

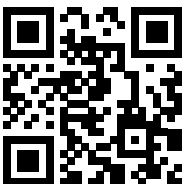

For more information on emergency procedures, view the Emergency Information Calendar, or download directly by scanning the QR code on the left.



Media contacts

On-call media representatives

- Georgia Power Media Line: 404-506-7676 or 800-282-1696
- Southern Nuclear Media Line: 205-992-5395

Websites

- www.georgiapower.com
- www.southerncompany.com

Social media channels

- Facebook: facebook.com/GeorgiaPower
- Twitter: twitter.com/GeorgiaPower
- Instagram: instagram.com/ga_power
- LinkedIn: linkedin.com/company/georgia-power-company

During an emergency

- Georgia Power Corporate Media Center (CMC)
(Activated only in the event of an emergency at the plant)
404-506-7676 or 800-282-1696
- Plant Hatch Joint Information Center (JIC)
(Activated only in the event of an emergency at the plant)
800-282-1696
- Plant Hatch recorded information line with most current update
(Activated only in the event of an emergency at the plant)
800-847-1186



Contacts for federal, state and local agencies

Federal agencies

- Nuclear Regulatory Commission
Public Affairs, Region II, Atlanta
opa2@nrc.gov or 404-562-4416 or 4417 (during business hours)
After hours, call the NRC Headquarters Operations Officer in Rockville, Md.:
301-816-5100
www.nrc.gov
- Federal Emergency Management Agency
770-220-5200 (24 hours)
www.fema.gov

State agencies

- Georgia Emergency Management & Homeland Security Agency
Public Information Officer, Atlanta
800-879-4362 or 800-TRY-GEMA
www.gema.georgia.gov

Local emergency management agencies

- Appling County Emergency Management Agency
912-367-8170
www.applingema.com
- Jeff Davis County Emergency Management Agency
912-375-6628
jeffdavisema.com
- Tattnall County Emergency Management Agency
912-557-6820
tattnallcountyga.com/emergency-management-agency.cfm
- Toombs County Emergency Management Agency
912-526-6424



Plant Hatch facts and statistics

Owner

Georgia Power (50.1%), Oglethorpe Power Corporation (30%), Municipal Electric Authority of Georgia (17.7%), Dalton Utilities (2.2%)

Operator

Southern Nuclear

Location

Appling County on the southern bank of the Altamaha River.

Nearest city

Baxley, Georgia, 11 miles south

Acreage

2,224 acres

Reactors

Boiling water reactor (BWR)

Rated capacity(size)

924 megawatts per unit

Reactor manufacturer

General Electric Company

Turbine generator manufacturer

General Electric Company

Containment building

General Electric Mark 1-Pressure Suppression

Construction start date

1968

Commercial operation

- Unit 1: December 31, 1975
- Unit 2: September 5, 1979

Cost

\$934 million

License renewals

Granted January 15, 2002

- Unit 1: August 6, 2034 (originally licensed until 2014)
- Unit 2: June 13, 2038 (originally licensed until 2018)



Employment

Approximately 900

Architect/Engineer

- Bechtel Power Corporation
- Southern Company Services, Inc.

Fuel (array):

- Fuel assemblies: 560
- Overall length of fuel assembly: approximately 14 feet
- Fuel rods per assembly: 90-100

Control rods (rod cluster control assemblies – RCCA)

- 137 rods for each unit
- Control rods per RCCA: 24
- Absorber material composition: boron carbide granules and hafnium rodlets
- Cladding: Type 304 stainless steel

Emergency power

- Diesel generators: Two dedicated per unit and one shared
- Rated capacity: 3MW each

Reactor coolant system (RCS)

All piping directly connected to the reactor vessel inside the drywell. Operates at a nominal pressure of 1,035 psig (pounds per square inch gauge).

Cooling water systems (CWS)

The condenser is cooled by the circulating water system, which transfers heat to four mechanical forced-draft cooling towers per unit. The water lost due to evaporation during the cooling process is replenished by water from the Altamaha River.



Our fuel

Plant Hatch generates steam with the use of ceramic pellets made of uranium. The uranium ore is mined, processed, enriched and formed into cylindrical fuel pellets.

The pellets, each about the size of a pencil eraser, are arranged in long vertical tubes bundled together to form one fuel assembly. There are 560 individual fuel assemblies that make up each reactor core at Plant Hatch.

Our uranium fuel does not burn chemically. The heat needed to create steam comes from the splitting of atoms, a process called fission, inside each pellet. Fission occurs when a uranium atom absorbs a neutron and the atom splits to create heat. Additional neutrons are also released, and they go on to split more atoms, creating a sustainable chain reaction.



Fuel assembly, fuel rod, cladding, fuel pellet

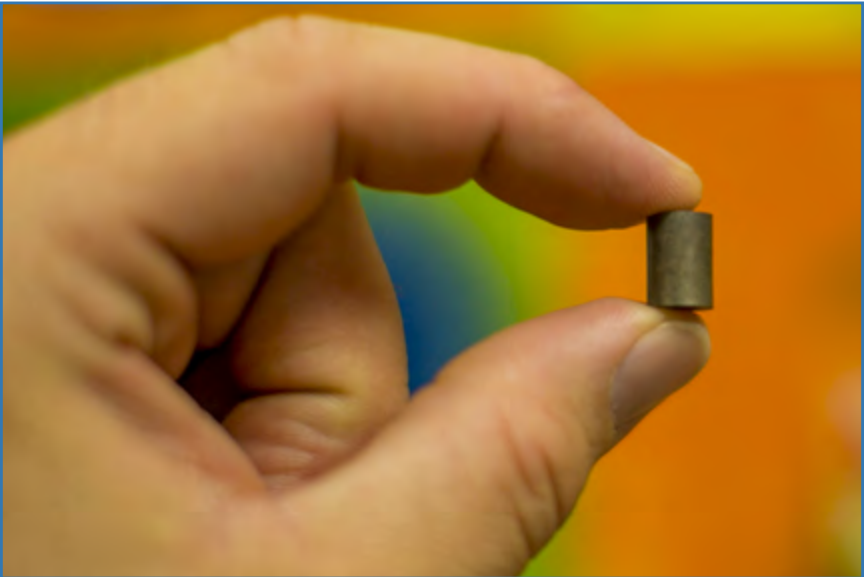

Fuel pellet



How Plant Hatch works

- 1 Water is pumped through the reactor core where the fission process boils the water into steam.
- 2 The steam goes to the turbine and spins the turbine blades.
- 3 The turbine spins the electric generator to produce electricity.
- 4 The steam goes to the condenser where it turns to liquid again to continue the cycle.
- 5 The water that circulates through the condenser is cooled by large fans in the cooling towers.

Note: The two water systems used to generate electricity are separate and don't mix with each other.

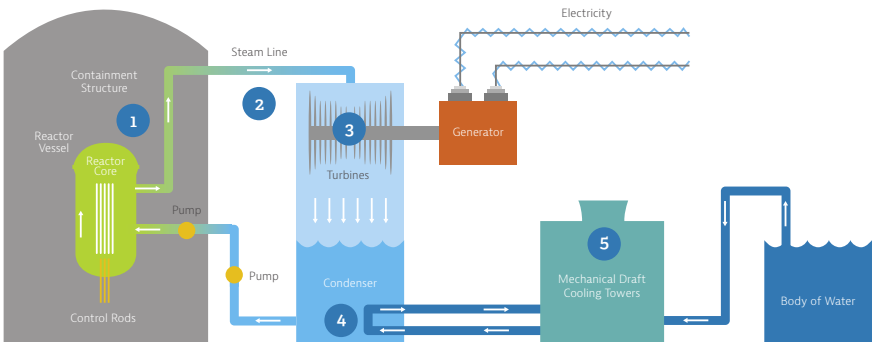



Storage of used fuel

Every nuclear plant in the U.S. safely stores used nuclear fuel assemblies on-site in indoor concrete pools or in storage canisters.

Spent fuel pool

When much of the uranium has been used in the fission process, the fuel assemblies are removed and replaced with new fuel assemblies. The used fuel is stored in spent fuel pools – steel-lined concrete pools filled with water. Water and concrete are excellent radiation shields, and in the spent fuel pools, water prevents radiation from emanating outside the pools. The water also keeps the fuel cool while the fuel becomes less radioactive over time.

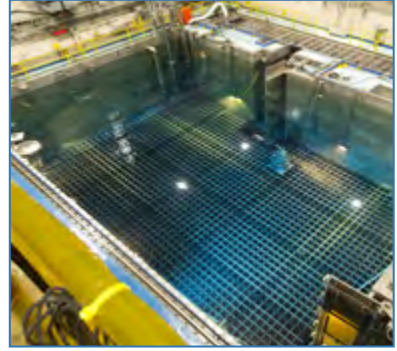

Spent fuel pool

Dry storage

Plant Hatch also uses dry canister storage to safely store used fuel on the plant site. Dry storage canisters are cylindrical containers constructed of steel-reinforced concrete, which serve as proven, effective radiation shields. These canisters effectively shield the radiation as the used fuel continues its cooling process.



Dry canister storage

The NRC requires dry storage canisters to be constantly monitored and relicensed every 20 years. The naturally cooled and ventilated containers are designed and tested to prevent the release of radiation under the most extreme conditions – earthquakes, tornadoes, hurricanes and floods.

These storage areas are well protected by a combination of sturdy construction, state-of-the-art surveillance and detection equipment, and armed security forces.



Radiation

The combined effect of the structural, mechanical and human safety systems built into our nuclear plants means that a person living within a few miles of a plant receives less radiation from Plant Hatch's operation than from watching television.

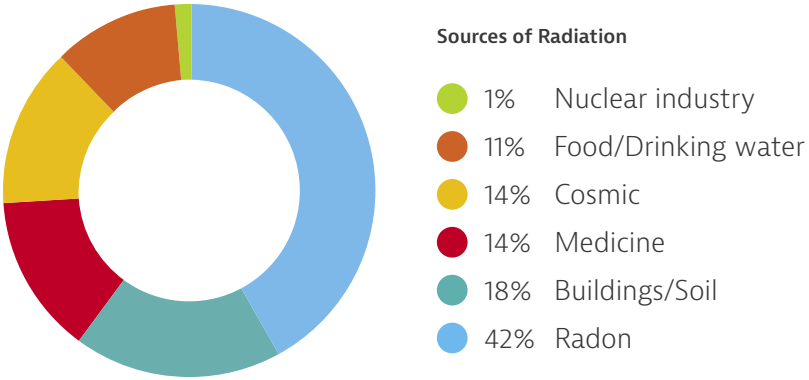

Radiation absorbed by the human body is measured in millirem. The average background radiation from our natural environment (sunlight, rocks, soil, food) and man-made sources of low-level radiation adds up to approximately 300 millirem a year.

For more information about radiation, please visit the Centers for Disease Control and Prevention's website.



Who was Edwin I. Hatch?

The plant is named for Edwin I. Hatch, who served as president of Georgia Power from 1963 until 1975. Under his leadership, Georgia Power more than tripled its generating capacity, multiplied its construction budget five times over and increased its customer base by more than 50 percent.

At the time of his retirement, Mr. Hatch cited the development of nuclear power as a carbon-free energy source as one of the most significant developments during his tenure.

Edwin Hatch died in 1997 at the age of 84.

Georgia Media Line: 800-828-1696

Southern Nuclear Media Line: 205-992-5395